

TREBUCHETS

KELVIN® Stock # 651667

DESIGN IT! ENGINEERING IN AFTER SCHOOL PROGRAMS

Education Development Center, Inc.

Table of Contents

Overview	3
Activity 1: Assembling a Trebuchet	11
Activity 2: Finding the Best Load	25
Activity 3: Adjusting the Balance Point.....	37
Activity 4: Sinking the Fleet	47
Appendix.....	55
Reference Materials	57
Letter to Families	59
Kelvin Materials Order Form.....	61

Activity 1: Assembling a Trebuchet

Before there was gunpowder, people built huge wooden and metal trebuchets (tre-boo-SHAY) that could throw very big rocks at castles or ships. In this project, you will make a model of one of these machines and become an expert at using it.

What Materials Do I Have?

- | | |
|---|--|
| ¥ 2 1-gallon plastic milk jugs with tight fitting caps (to act as towers) | ¥ 3 rubber bands (#64 or thicker) |
| ¥ 2 yardsticks | ¥ 1 sheet of paper |
| ¥ 1 12-inch ruler | ¥ 2 binder clips |
| ¥ 2 20-inch wooden dowels | ¥ masking tape and duct tape |
| ¥ 1 4-inch wooden dowel | ¥ boxes, file crates, books (to raise height of milk jugs) |
| ¥ 1 Styrofoam cup (6-ounce or 9-ounce) | ¥ bowls, boxes (to build targets) |
| ¥ 20 steel washers (approximately 1-1/2 inches in diameter) | ¥ <i>Data Sheet—Activity 1</i> |

THE CHALLENGE

Assemble a trebuchet with the materials you have been given and make it work.

What Do I Do?

Look at the figure of the trebuchet on page 13. Notice all the parts and how they fit together. Use the picture and the instructions below to help you build your own model trebuchet.

1. The yardstick will be your throwing arm. Attach the yardstick to the dowel using a rubber band. This makes the fulcrum (balance point) of the throwing arm.

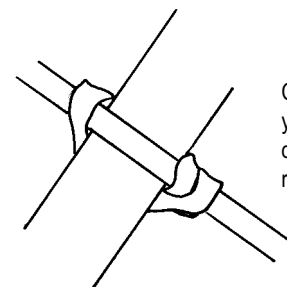

Connecting the yardstick to the dowel using a rubber band

Challenge Sheet

- Slide the dowel up or down the yardstick so that the fulcrum is at the 8-inch mark (as shown at right).
- Use a weight (load) of 20 washers and attach it to the short end of the throwing arm (as shown below).

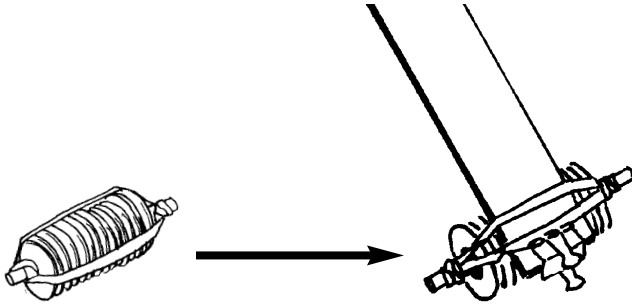
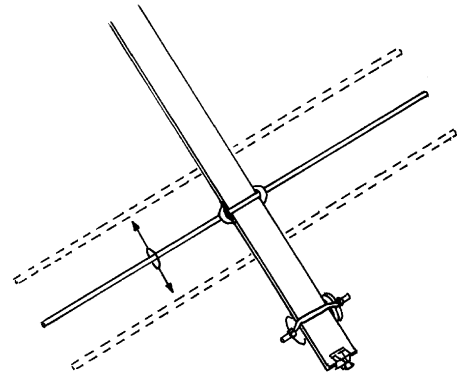

- Cut the top half off the Styrofoam cup (so it is about 2 inches deep). Fix it to the top end of the throwing arm to hold a cannonball
- Make a cannonball out of a single sheet of paper and tape. See how far you can shoot it.
- After you have experimented with this machine for a while, you may be able to pass on some tips to other teams about what works and what doesn't. Write your suggestions on the *What Works?* chart on *Data Sheet—Activity 1*.

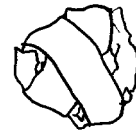

Paper cannonball

What to Think About

- ¥ What is working and what is not working on this machine?
- ¥ What changes would make the cannonball go farther?

SAFETY

- Shoot *only* paper cannonballs.
- Aim your cannonball away from people.
- Do not shoot the cannonball by hitting or pushing the yardstick with your hand (or anything else).

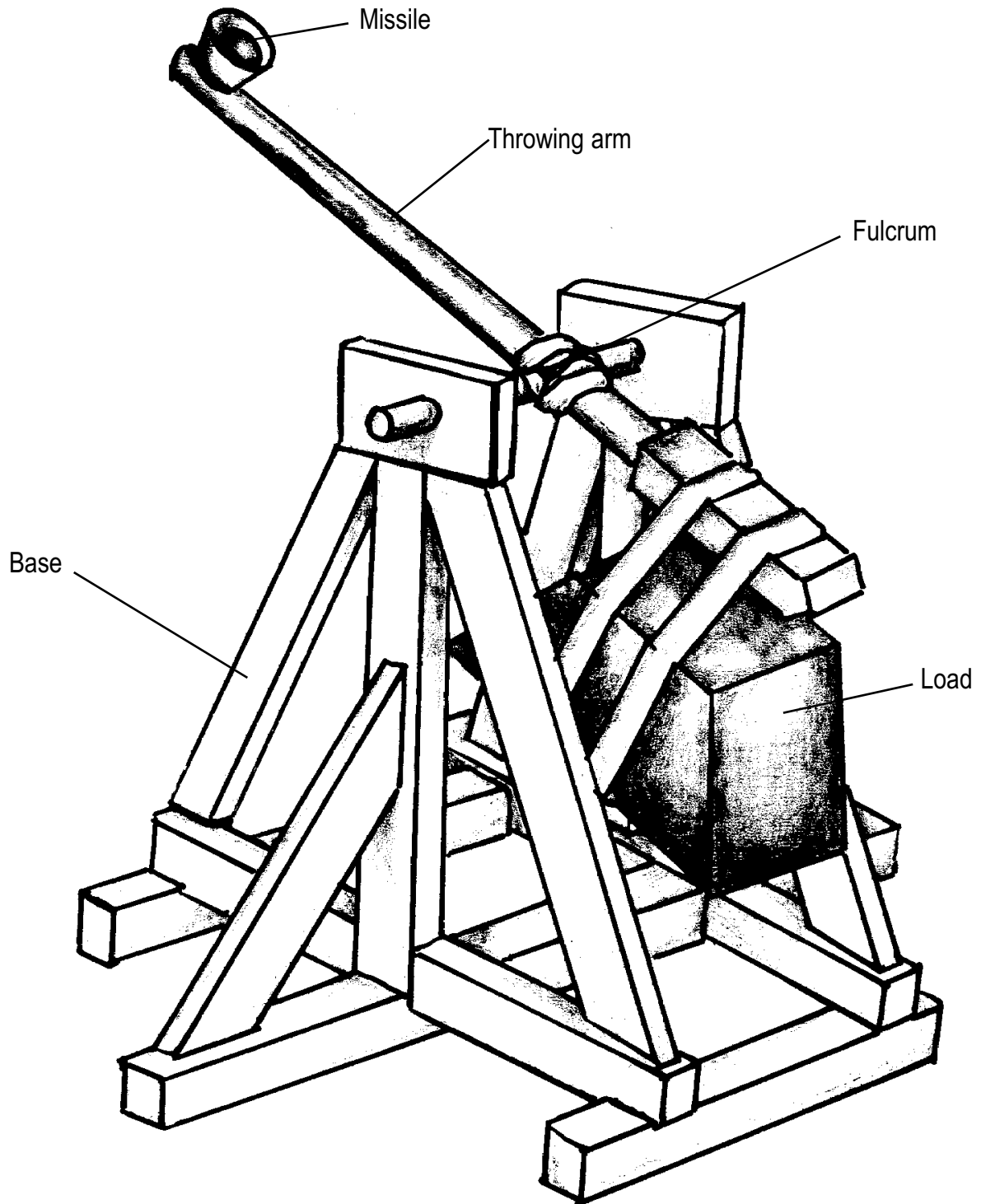

Data Sheet—Activity 1

Team Members: _____

After you have experimented with this machine for a while, you may be able to pass on some tips to others about what works and what doesn't. Write down your suggestions here.

What Works?	What Doesn't?

Activity 1: Assembling a Trebuchet

PREPARING AHEAD

- ¥ Gather enough materials for every team to make a trebuchet.
- ¥ Cut the dowels to the lengths indicated using scissors, wire cutters, or a saw. If your children can use sharp implements safely, you may let them do this part for themselves.

SAFETY

Always supervise children when they use sharp tools.

- ¥ Fill the milk containers with water (or sand, if available).
- ¥ Find enough boxes or books so that every team can raise their milk jugs at least 8 inches off the table or floor.
- ¥ Assemble a trebuchet yourself, and practice using it.
- ¥ Make enough copies of the Challenge Sheet, including *Data Sheet—Activity 1*, for each team.

INTRODUCING THE ACTIVITY

Show the children a picture of a trebuchet machine (see the Challenge Sheet and page 20). Ask them, What do you notice about this machine? Probe for comments on its size, design, materials, history, and how it was used. Ask the children how they think the machine works and have them describe the various parts and what each part does. Tell them the trebuchet was invented over 1,000 years ago. It was used in Europe, China, and the Arab countries to attack stone castles or ships.

Explain that you are about to give them some materials that can be used to make a machine just like the one in the diagram.

THE CHALLENGE

Assemble a trebuchet with the materials you have been given and make it work.

Go over the safety guidelines listed on the Challenge Sheet for Activity 1.

As soon as you are sure that most of the children understand how to construct the model, hand out the Challenge Sheet, including *Data Sheet—Activity 1*, and the materials, and let them begin working.

Materials

FOR EACH TEAM

- 2 1-gallon plastic milk jugs with tight fitting caps
- 2 yardsticks
- 1 12-inch ruler
- 2 wooden dowels (1/4-inch diameter, 20 inches long)
- 1 wooden dowel (1/4-inch diameter, 4 inches long)
- 1 Styrofoam cup (6-ounce or 9-ounce)
- 20 steel washers (approximately 1-1/2 inches in diameter)
- 3 rubber bands (#64 or thicker)
- 1 sheet of copier paper
- 2 binder clips
- boxes, file crates, books
- bowls, boxes
- *Data Sheet—Activity 1*

FOR THE WHOLE GROUP

- masking tape and duct tape
- scissors
- index cards
- pencils
- sand (optional)

FOR THE PROGRAM LEADER

- scissors, wire cutters, or a saw

LEADING THE ACTIVITY

Construction problems: Assembling the trebuchet

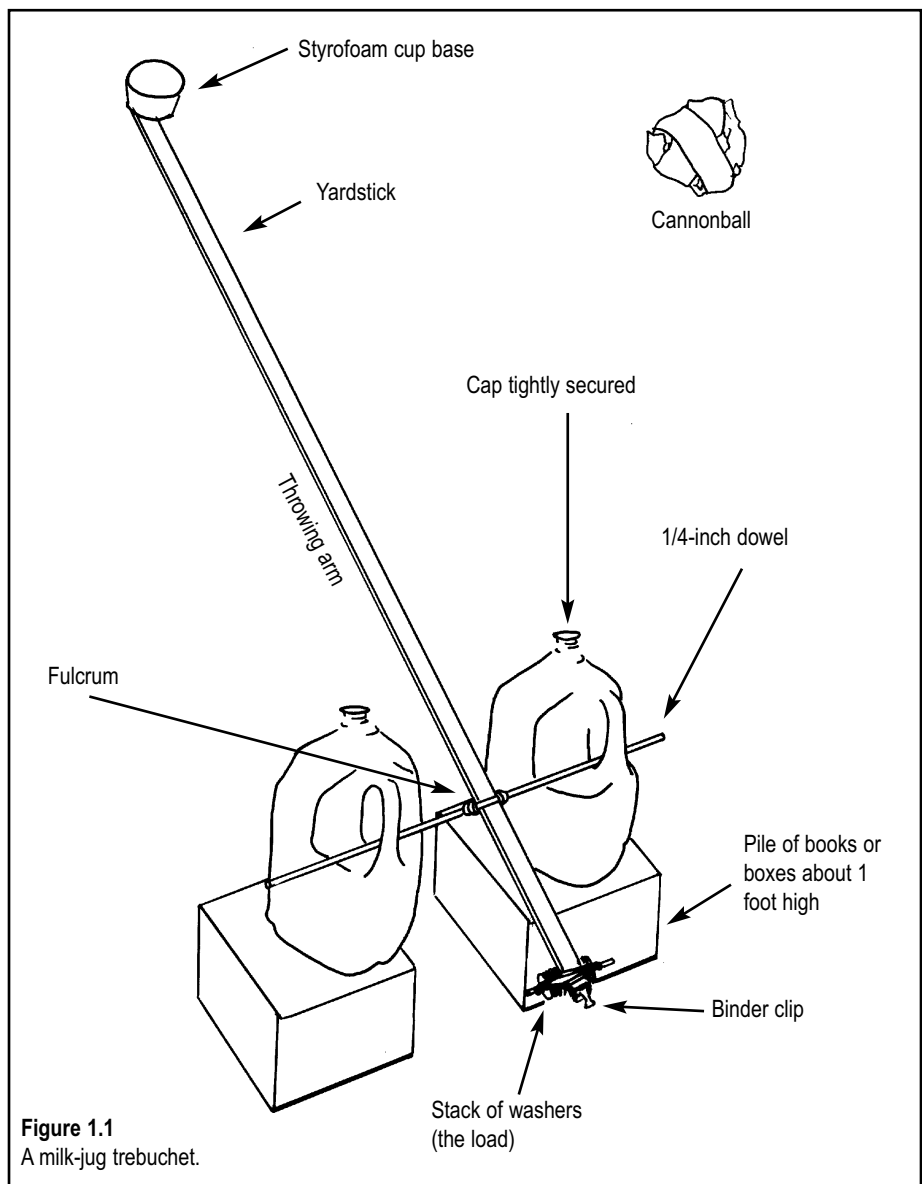

It would be unrealistic to ask the children to invent the trebuchet from scratch. So instead, show them the historical depiction of the trebuchet (see pages 13 and 20) to give them a good idea of what their final product will look like. Their task is to recreate that design as best they can with the materials you give them. Avoid showing them the diagram of the milk jug trebuchet (Figure 1.1) until they have had a chance to try out their own ideas. Hopefully they will come up with something that looks pretty similar to the one shown here or something else that works just as well.



Guiding the Activity

Table 1.2 gives some hints about design problems the children may run into as they put their machines together.

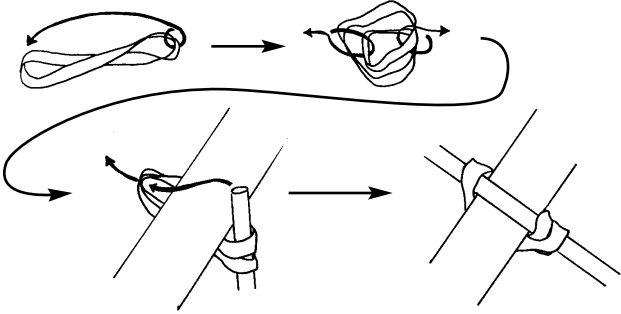
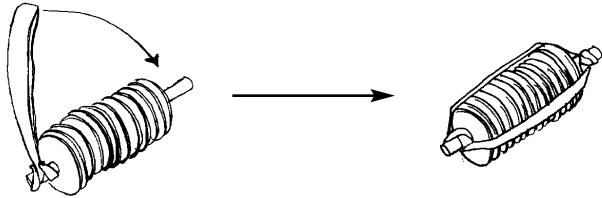
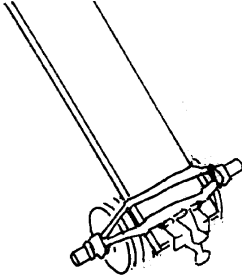
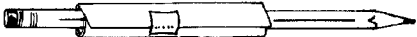
Table 1.2

Problem	Possible Solution	Image
<p>Difficulty making the fulcrum.</p>	<p>Attach the yardstick to the dowel with a rubber band as shown. Do not use tape. This connection should be tight, but children should still be able to move the dowel up or down the yardstick. This will be important later.</p>	
<p>Difficulty making a load.</p>	<p>One way to make a load is by using a small piece of dowel, a stack of 20 washers, and a rubber band. Children could also tape stacks of washers or nails together.</p>	
<p>Load falls off end of throwing arm.</p>	<p>Use binder clips to attach the rubber band to the end of the yardstick.</p>	
<p>Difficulty attaching the dowel to the milk jugs.</p>	<p>Either slip the dowel through the handles of the jugs and tape them in place, or make two small tubes by rolling up index cards around a pencil. Tape these to the sides of the jugs and slip the ends of the dowel into each one.</p>	
<p>Difficulty attaching the cannonball holder.</p>	<p>Use masking or duct tape (folded in a loop) to fix the base of the Styrofoam cup to the top end of the throwing arm.</p>	

Design problems: Making it shoot straight

Even though the throwing arms may swing very nicely, a number of other factors need to be just right if the cannonball is to launch in the right way. Common problems are that the throwing arm slides out of position, the cannonball falls out of the cup at the back of the swing, or (the opposite problem) it slam dunks into the floor right in front of the trebuchet, meaning that it holds onto the cannonball too long. Ask the children for their ideas on how to solve these problems before you give them the hints listed in Table 1.3.

Table 1.3

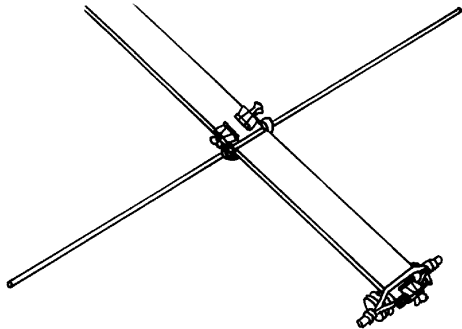
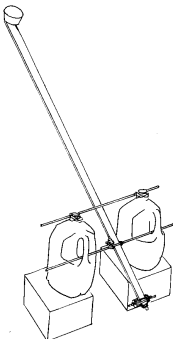
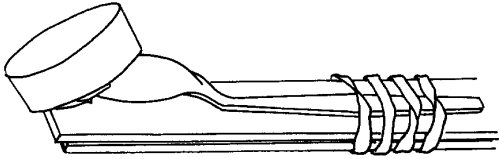
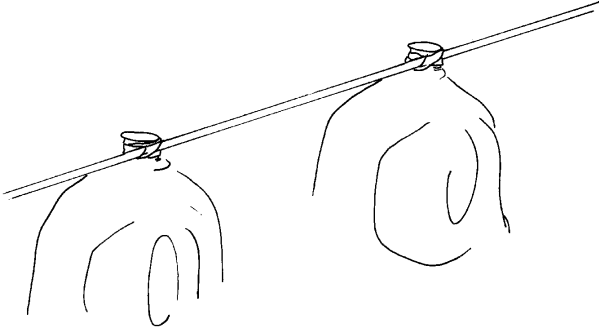
Problem	Possible Solution	Image
<p>The fulcrum slides off the 8-inch position.</p>	<p>Place a binder clip on each side of the yardstick just above the dowel to stop the yardstick sliding out of position. Don't let the children use tape. This will prevent adjustment of the fulcrum position later.</p>	
	<p>Cut down the depth of the cup. Cut a little at a time until it is just the right size.</p>	<p>NO DIAGRAM</p>
<p>Slam Dunk!</p> 	<p>Slide a plastic spoon under the cup so that it tips back slightly. Experiment to find the right angle.</p>	
	<p>Place a second dowel on the milk jugs to stop the top half of the throwing arm as it swings around. Adjusting the exact position of this second dowel will change the way the device fires the cannonball.</p>	

LEADING THE DISCUSSION

After the children have assembled their models and tested them, gather all of the teams together to share what they have achieved so far. If your space allows you to, lead the whole group from one trebuchet to the next and spend a few minutes as a group examining each design and watching it shoot. As you go to each device, have the home team explain their design to the group and tell what did or did not work well.

After you have visited all the teams, gather the whole group away from the trebuchets and ask them what they have learned about how to make and operate a successful trebuchet. Give them a few minutes to write some ideas on their own *What Works?* charts. Then set up a big *What Works?* chart in your room and collect their ideas onto the one chart. To stimulate their thinking, ask any of the following questions (or others) about the design and operation of the machine. At the end of the discussion, you should have a master list of the children's understandings of the assembly and usage of a trebuchet.

Construction questions

¥ Do the towers (jugs) need to be the same height? What happens if they are not?



¥ What is the best way to make the fulcrum joint tight and set it at the 8-inch mark? What happens if it is not tight or not at that position?

¥ How can you make sure that the throwing arm can swing freely? Does anything block it? Does it wobble? Does that matter?

Operations questions

¥ What is the best height of the jugs from the table or floor?



¥ How far back should the arm be pulled?

¥ What is the best way to attach the throwing cup? Is there any special way that it should be positioned?

NOTE ABOUT TEAMWORK: The roles that were assigned to the members of the teams will work best if you make a point of reinforcing them often throughout the project, especially in the early sessions. During the discussion and sharing times, be sure to ask each team how the division of labor worked out. When asking for information from the team, ask who the presenter is and call upon him or her first. Also check if the ambassador learned anything from other teams and how others carried out their roles.

Figure 1.4
A historical depiction of a trebuchet c. 1500.

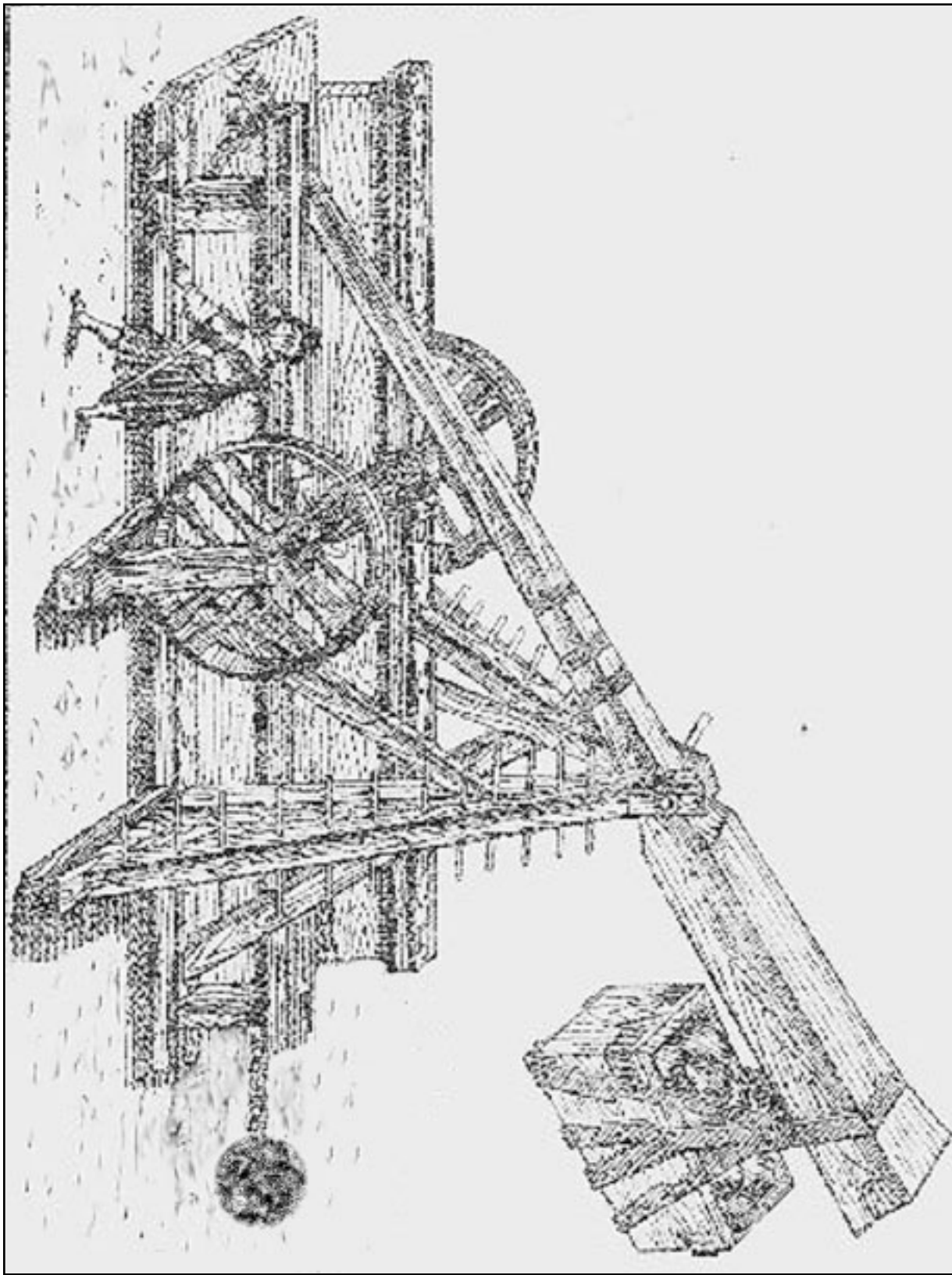

Activity 1: Assembling a Trebuchet

RATIONALE

However complicated it looks, the trebuchet is really nothing more than a modified seesaw or lever. Its simple design makes it an appropriate device for children to study; it functions with principles that they have already come across many times in their lives and that they will continue to come across for a good deal longer. So, in addition to all the challenges involved in assembling and handling the materials themselves, this device offers an excellent way for children to gain an understanding of how balancing and turning forces work together.

INTRODUCING THE ACTIVITY

Various people around the world have built full-scale trebuchets in recent years. One such project was filmed by the PBS NOVA documentary team in their series *Secrets of the Lost Empires*. For your own education, it would be good to view as much of this material as you can before beginning to work with the children. There are also several Web sites that give a great deal of extra information about trebuchets (see Reference Materials, page 57).

Share the image of a trebuchet on page 20 with the children at the beginning of the project. However, it is not recommended that you show too many other images of medieval trebuchets *at the very beginning of the project*. Doing so tends to take away the chance for the children to be inventive about how the machine works; when they see the real thing they often think they have to make theirs look exactly the same rather than working out what works best with the materials they are using. Another problem is that the real machines use a sling device at the top end of the throwing arm to give extra power to the cannonball. This detail is very hard to duplicate in miniature and, for that reason, is not suggested for this project. If you show video and Web images *after* rather than before doing the project, you can all decide whether you want to take on the extra challenge of adding a sling, and you can discuss how and why your trebuchet is the same as or different from the ancient ones.

LEADING THE ACTIVITY

The main engineering issue children will confront in this activity is overcoming the tendency of the machine to slam dunk when the throwing cup holds onto the cannonball too long. Careful adjustment to the angle of the cup (tipping it slightly back) can overcome the problem, but an easier solution is to find the best place to stop the throwing arm in mid-swing (with a second dowel) so that it launches the cannonball at just the right moment.

The second dowel is easier to set up, and it is obvious to children how it works. But before showing the children any of the ideas shown in this guide, give them a chance to invent their own solutions to the problem. Some children place books on the floor between the milk jugs so that the weights hit them on the way down. This has the same effect on the cannonball as the second dowel.

LEADING THE DISCUSSION

Findings and understandings

If the children look carefully at the details of their trebuchets (or any other device), they will notice that there are almost always features of the machine that can be changed (by the user) to make it work better. They will find that if they do some particular thing, their trebuchets will respond in a predictable way (as long as they don't change other things from one test to the next). In Activities 2 and 3, the children will investigate the relationship between the amount of load or the position of the fulcrum and how far the cannonball flies. They may notice, for instance, that at first when they put on more load, the cannonball goes farther. But after a certain amount of load is added, adding even more makes no difference. They may also notice other things that make a difference (the size of the cannonball, the height of the milk jugs, etc.).

In your discussions with the children, and as all of you fill out the *What Works?* chart, see if you can get them to say what they think are the useful findings and understandings about this machine that could be passed on to other users. The intent is to have the children state those findings they believe to be true and which seem to have been verified by experience so far. For example:

- ¥ The jugs have to be level to make it shoot straight.
- ¥ The cup has to be tipped back just a little to stop slam dunks.
- ¥ If you put more load on, it shoots farther (up to a point).
- ¥ If you put clips above the fulcrum, it stops the arm from sliding down.

Remember that it is not important that you agree with these statements, nor even that they be true. Your role is to coax the children to make whatever such statements they believe make sense and then to help them carry out tests that let them check to see if they really hold up.

Teamwork

If the division of labor within the teams or the nature of the roles themselves is not working for you, or if it seems unfair to the children, ask them to help you redefine the roles. If necessary, reassign the roles to the children within some teams, and as a last resort, reassign children between teams. Several times during this project you should ask the teams to rotate the roles, so that everyone gets a chance to try each one at least once. Be sparing about reshuffling teams, however. It is better for the children to confront and solve (with your help) the problems than for you to always intervene.

SCIENCE BACKGROUND

The Trebuchet Is Like an Unbalanced Seesaw

In cartoons, we often see one character (usually very large) jumping onto one side of a board (balanced in the middle) and as a result, sending another character (smaller and sitting innocently on the other end) soaring into space. Cartoonists are not always accurate physicists, but the scenario *is* based in reality. If a large enough force is applied to the short end of a seesaw, it can produce a dramatic reaction at the other (long) end. How dramatic depends on several measurable factors:

- the weight and speed (momentum) of the “jumper,”
- the weight of the “victim,” and
- the relative lengths of the two sides of the seesaw.

The trebuchet is very similar to the dog and cat cartoon in Figure 1.5, except that in a trebuchet, no one actually jumps onto the short end; real trebuchets were far too big and heavy

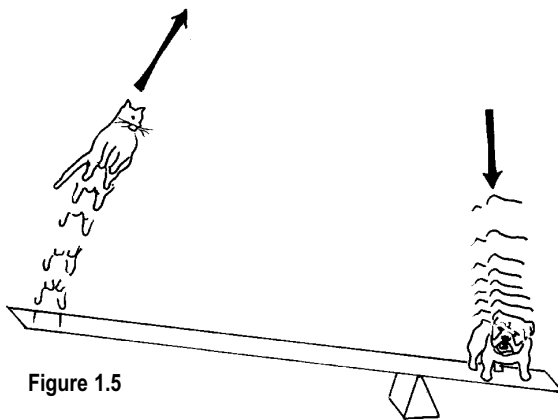

Figure 1.5

for that (see Figure 1.4 on page 20). Instead, on a medieval trebuchet, a long (and very heavy) wooden beam was balanced unevenly over a high fulcrum. Attached to the short end of the beam was a very heavy weight—many tons, perhaps. At the far tip of the long end of the beam was the cannonball—a rock or burning “bomb” of some sort. Human (and perhaps animal) power was used to slowly raise the short, heavy end of the beam up as high as it could go. Once there, it was locked into place until every-

thing was ready. When a trigger was pulled, the weight plunged downwards, making the long end of the beam swing very fast over the top, hurling the cannonball at the enemy castle or ship.

When the short, heavy end falls down, it actually turns around a part of a small circle (see Figure 1.6). Meanwhile, the long end of the beam is forced to swing around a circle too, but because the circle is so much bigger, that end of the beam has to travel much faster to keep up; that is what gives the cannonball its speed.

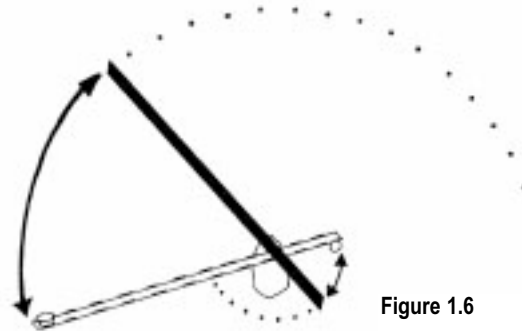

Figure 1.6

ASSESSMENT

During this first activity you will get a general sense of how the children go about the construction and design process. To help you measure whether they are getting better at this process as they move through the project, take some time now to make notes about the following points. You can ask these questions with respect to the whole group or an individual child. Later you can compare behavior to see if changes have occurred.

To what extent does the team (a child):

- ¥ assemble the machines in a careful or haphazard manner?
- ¥ think ahead before taking an action?
- ¥ consult with others before taking an action that affects the whole team?
- ¥ adjust the design of the trebuchet based on its performance?
- ¥ try to solve problems themselves before asking for help or giving up?
- ¥ accept help from you or from each other?

