

# BALLS & TRACKS

KELVIN® Stock #651666

**DESIGN IT! ENGINEERING IN AFTER SCHOOL PROGRAMS**

Education Development Center, Inc.

# Table of Contents

Overview .....	3
Activity 1: Building a Ski Jump .....	11
Activity 2: Creating Hills and Valleys .....	25
Activity 3: Adding Loops and Spirals .....	37
Activity 4: Running the Obstacle Course.....	49
Activity 5: Designing a Super Coaster .....	57
Appendix.....	63
Letter to Families .....	65
Kelvin Materials Order Form .....	67

## Activity 1: Building a Ski Jump

Have you ever watched ski jumpers at the Winter Olympics or skateboarders on a ramp? If you have, you know that you can become airborne if you get enough downhill speed and then turn up into a short uphill section. See if you can make the marble do the same with the track provided.

### What Materials Do I Have?

- foam insulation tubing (6 feet total length)
- glass marbles
- 1 Popsicle stick
- empty coffee cans (or similar) to use as targets
- yardstick or measuring tape
- masking tape and string
- 1 large, empty cardboard box
- *Data Sheet—Activity 1*

### THE CHALLENGE

Design a ski jump that makes your marble jump into a can without bouncing on the floor. How far can the marble jump and still land in a can?

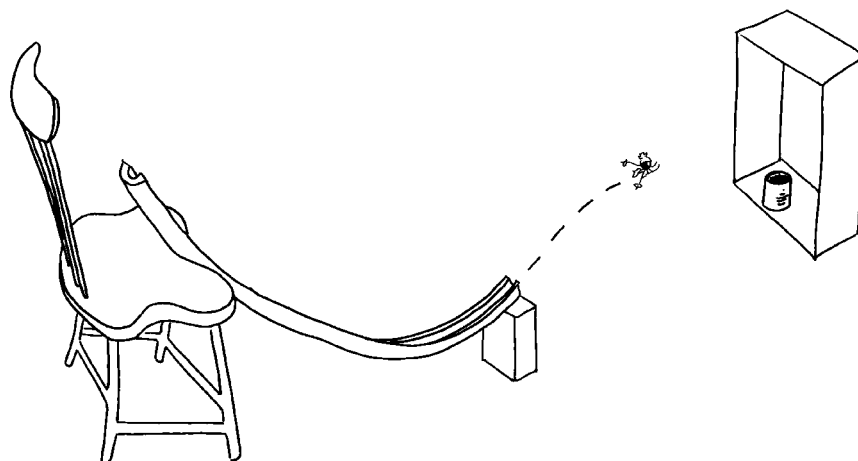

## What Do I Do?

1. If necessary, join the pieces of pipe into one track.
2. Tape the track to the wall of your room or to a chair or other fixed object.
3. Place several target cans on the floor in line so the marble can land in one of them.
4. Place a cardboard box behind the farthest can to catch marbles that sail over all the cans.
5. Release one marble at the top of the track, using the Popsicle stick. DO NOT push the marble downward when you release it!
6. Adjust the shape of the track and the position of the cans so that the marble lands in the farthest can.

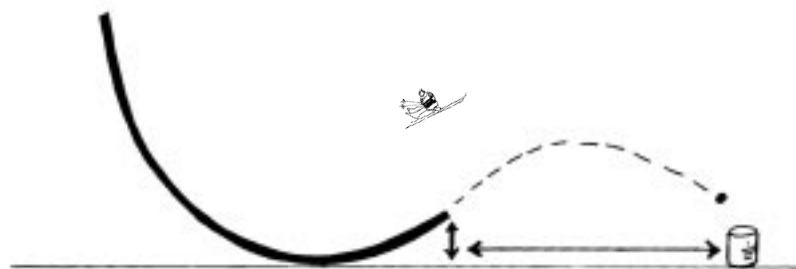
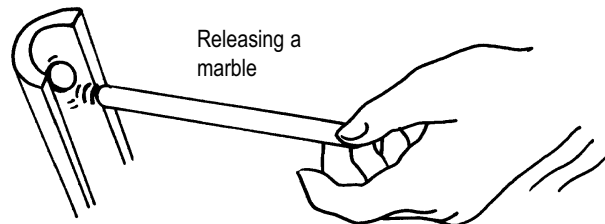

Measure from the end of the track to the beginning of the can.

7. Make up a game in which you score a different number of points for each target can. Figure out the best place to release the marble for each target can.
8. Make a diagram of your best ski jump on *Data Sheet—Activity 1*. Then record on the *What Works?* chart what worked and what didn't while designing your best ski jump.

**SAFETY:** Use the tracks and the marbles **only** in the way described.

## What to Think About

- What happens if the track is not fixed securely to something stable (a wall or furniture)?
- What track shape makes the marble go farthest?

## Data Sheet—Activity 1

Team Members: \_\_\_\_\_  
\_\_\_\_\_  
\_\_\_\_\_

Make a diagram of your best ski jump below. show how high you released the marble for each target can.

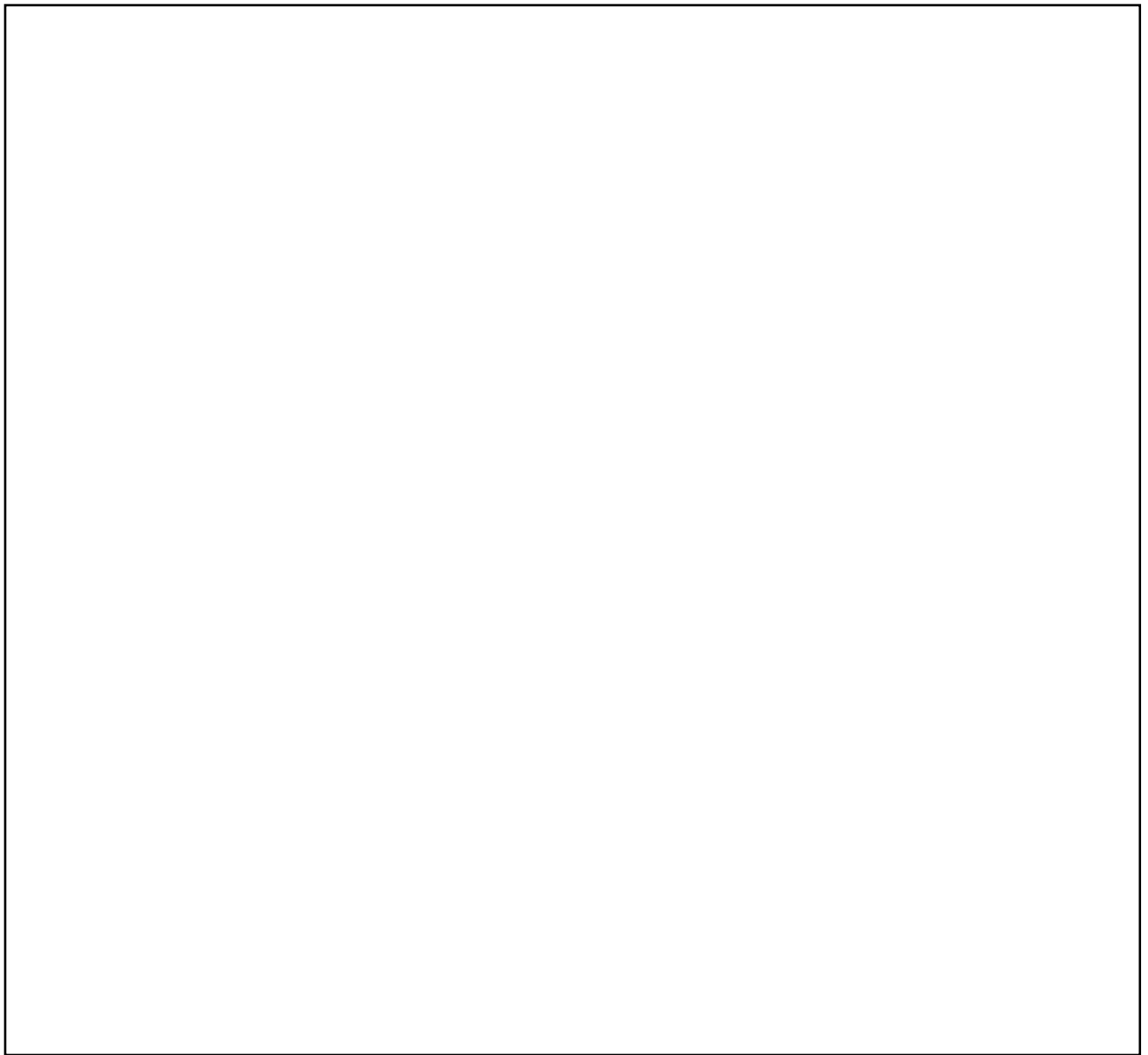

## Data Sheet—Activity 1

Use this chart to record what you discover about how to make a good ski jump.

<b>What Works?</b>	<b>What Doesn't?</b>

# Activity 1: Building a Ski Jump

## PREPARING AHEAD

- Gather the materials for this activity. Slit the insulation tubing down the middle to make two half-round troughs from each. You will see that there is already a slit down one side. Open this up with your fingers and use sharp scissors or a craft knife to cut the other side. Try to make the halves as even as possible.
- Make your own ski jump before doing the activity with the children. See what works and what problems arise. Doing a test run will make it much easier for you to anticipate any problems the children may experience.
- Before the children begin, think about how to arrange the teams within the space you have available. Each team will work with 6 feet of track. The marble may jump almost 3 feet beyond that, so you need about 10 feet of floor space or corridor for each team to be comfortable. If you have a lot of free wall space, then you can space the teams out along this and the children can tape their tracks along the wall and floor. If you do not have enough wall for this, each team should attach the high end of their track to a table or chair (or wall or file cabinet) and use other furniture or books to support the rest of the track (see illustration on page 11).
- Prepare a folder and some drawing paper for the children to make diagrams of their ski jumps before they take them apart at the end of the session.
- Make enough copies of the Challenge Sheet, including *Data Sheet—Activity 1*, for each team.

## INTRODUCING THE ACTIVITY

### *Being an engineer*

Set the scene by telling the children they will be forming teams of *engineers* to build games using marbles and tracks. Ask them what they think engineers usually do and how they work. Have the children brainstorm some of their ideas, record them on chart paper, and then hang the list on the wall. Write down whatever the children say, but be on the lookout for the ideas mentioned in the first section of the *Implementation Guide to Design It! Projects*.

### *Ski jumps*

Ask the children if they have ever seen a real ski jump in the Winter Olympics, either on TV or in person. If you can, find a picture in a magazine or on the Internet of a skier flying through the air. Ask the children, “What’s pushing this person through the air?” and “How did he or she get to be going so fast?”

## Materials

### FOR EACH TEAM

- foam insulation tubing (6 feet total length)
- glass marbles
- 1 Popsicle stick
- masking tape and string
- empty coffee cans
- yardstick or measuring tape
- 1 large, empty cardboard box
- *Data Sheet—Activity 1*

### FOR THE PROGRAM LEADER

- craft knife

Explain the challenge. The goal is for the marble to land directly in one of the cans without bouncing on the floor. In addition, they are to try to get the marble to jump as far as they can. Once they are sure that the marble can jump no farther, and once it lands in the farthest can almost every time they aim for it, everyone in the team should make a drawing on *Data Sheet—Activity 1* showing their design. The drawing should show how far the cans are placed away from the end of the jump and how high from the floor the marble was released when aiming for each can. For older children, this diagram should include accurate measurements of the length and heights of the parts of the ski jump.

### THE CHALLENGE

Design a ski jump that makes your marble jump into a can without bouncing on the floor. How far can the marble jump and still land in a can?

If you have not already done so, divide the group into teams of two or three children and assign a space for each team to work. State clear ground rules for behavior, including the acceptable use of the materials. Hand out the materials and let the children begin work.

### LEADING THE ACTIVITY

As the children work on their ski jumps, walk around the room and talk to them about what they are noticing and how it is working for them. Support their efforts and encourage them to look at what other teams are doing. To the extent that it helps them stay focused or overcome problems, ask questions about what they are doing, but try to avoid telling them how to make their ski jump. Even if you see them doing something that you *know* will not work, let them figure out what is wrong for themselves.

As you talk with the children ask (variations on) the three questions below. These questions are designed to get *them* to do the thinking. Do not give answers or solutions to their problems until they have made a sincere effort to answer one or all of these questions. Depending on their answers, you should ask follow-up questions that keep the thinking going. If they are having trouble moving forward and become frustrated, by all means, give them a hint.



- What works (and what doesn't)?
- What have you tried (and what happened)?
- What has worked for other teams? (Has the ambassador been looking at what other teams have been doing?)



**Troubleshooting**

It should be possible to make a glass marble jump between 2 and 3 feet from the end of the ski jump. Table 1.1 gives you some hints on what might be happening if the children are having trouble achieving this result.

Table 1.1

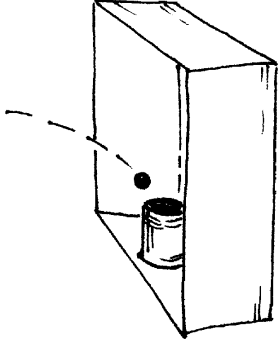
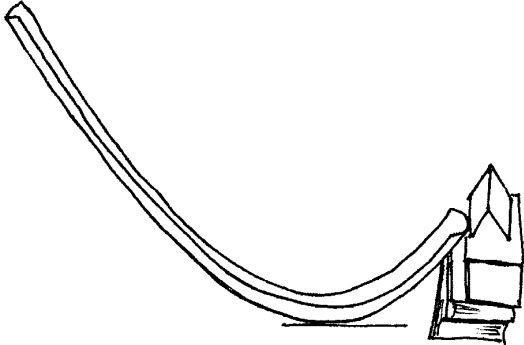
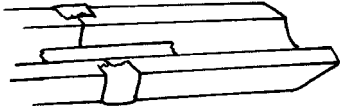
Problem	Possible Solution	Image
<p>Marble gets lost when it misses the can.</p>	<p>Set up a large cardboard box behind the farthest can to catch stray marbles.</p>	
<p>Marble won't jump up off the end of the track.</p>	<p>Make the last 6–12 inches of track turn upwards. Use a box or books to hold the end up. Adjust the angle of the upturn to find the best arrangement.</p>	
<p>Track wobbles or will not stay in constant position.</p>	<p>Where possible, fix the track securely to walls or furniture using masking tape or string.</p>	<p>NO DIAGRAM</p>
<p>Marble jumps off track where two pieces are joined.</p>	<p>Make sure the joint is smooth. Lay tape lengthwise along the trough over the joint.</p>	

After children have had sufficient time to build and test their ski jumps, tell them that first you want them all to walk around the room to look at each others' ski jumps. Explain that you will ask them to say two things during the Discussion Circle:

- One thing I really like about my own team's design is...
- One thing I really like about another team's design is...

When they have looked at each other's designs and told what they like about their own and other designs, send them back to make changes or refinements to their ski jumps. Remind them that the challenge is to see how far they can make the marble jump (and still land in a can) and also to see if they can find the best release point for the marble to land in each can.

## LEADING THE DISCUSSION

After children have had time to refine and test their designs, call the whole group together again for a final Discussion Circle. Make a large blank version of the *What Works?* chart on a chalkboard or chart paper. You will be adding to this list throughout the project, so make sure to leave plenty of room for later additions.

Begin by giving them a few minutes to fill out their own *What Works?* charts. Then have teams report out the first two or three items on each side of their charts. Write these on the class chart. When everyone has made their suggestions, go through the list together to see if there are any points that everyone agrees upon. If there are, put a large X next to that item or highlight it in some other way. Do not make any judgment about whether you think they are right or wrong. That is for them to discover in due course. To get the conversation going, or if you find that certain aspects of the ski jump are not being addressed, you may want to ask some of the following questions:

### *Construction questions*

- How did you stop the track from wobbling?
- How did you aim the marble for the can?
- How did you connect the track so the ball didn't catch on the joints?
- What makes the marble go faster or slower?
- What will happen if you make the track steeper?
- Where is the best place to start the marble rolling?

### *Design questions*

- What shape should the final section of track be for the longest jump?
- What features of the track might be making the marble slow down or speed up?
- What is the connection between the speed of the marble (at take-off) and how far it goes?
- How steep should the steepest part of the track be?

# Activity 1: Building a Ski Jump

## RATIONALE

Many children and adults have ridden on a roller coaster at an amusement park. Few have tried a ski jump. Anyone who has ridden a bicycle or skateboard over a ramp or a bump in the road, however, knows that if you are going fast enough before you hit the ramp or bump, you suddenly feel as though you have defied gravity and *taken off!* Activity 1 introduces the children to the materials they will use throughout the project and introduces the issue of “take-off,” which will come up again and again as they move on to designing different roller coasters during this project.

This activity, and those that follow, introduce children to basic engineering challenges. Children have to arrive at workable arrangements using the materials available to them. For the ski jump (and later, the roller coaster) to function well, the tracks must be supported so they stay in a fixed position.

## INTRODUCING THE ACTIVITY

A skier flying through the air after taking off from a ski jump is similar to a car, bike, or skateboard going over a speed bump or off a ramp at high speed. If you feel comfortable, you might extend this initial conversation by drawing out the children’s personal experiences with any of the devices that launch a person upwards in the way that a ski jump does.

## LEADING THE ACTIVITY

### *Questions*

This is your opportunity to model the types of questions that you want the children to ask themselves as they are engaged in the activity and that are important to the design process (such as those on page 16). The purpose of the questions is to get the children to observe how their construction works and how changes that they make affect its functioning.

### *Pacing*

The children will probably prefer to play with the materials in an uninterrupted way from the beginning of the session to the end, and may resist when you break into their playtime for a Discussion Circle. Nonetheless, it is strongly recommended that you keep control of the pace of the activity and intervene in the way described. Although exploration with the materials is essential to the learning process, stopping from time to time to consider what is happening is also an essential part of making sense of the experience. By looking at other people’s ski jumps and finding something

interesting or admirable in them, they may be more likely to make changes to their own designs if they are not performing as best they could.

## LEADING THE DISCUSSION

Formal discussions about design projects should be separate from the handling of the materials. Children often find it hard to switch from touching to talking, so it is important to make the transition very obvious. It is best if materials are left where they are while the children gather away from them in a Discussion Circle.

Discussions should be short, at first, centering more on setting up the habits and routines of discussion rather than getting to the whole truth of the matter. Eventually both can happen, but it might take a while, so try to observe the following guidelines from the beginning of your work with *Design It!* projects:

- Keep the early discussion short (5-10 minutes).
- Insist that only one person talk at a time.
- Insist on taking turns. Work out your own way to keep the system clear and consistent (hand raising, etc.).
- Reflect. Repeat back to the speakers the essence of what they said so they will know that they were heard and whether they were understood.
- Separate construction problems from design “findings.”

### *Construction problems*

Most construction problems have more than one solution. And in most teams, children find more than one way to solve a particular problem. Make sure you give time and space in the Discussion Circle for children to share their ideas and successes with the whole group. If no one comes up with any ideas for solving a particular problem, you may have to suggest a solution yourself. But avoid giving solutions unless the children aren't making any progress at all. Even then, be sparing with your hints. Make as much space as you can for the children to discover things on their own, and help them feel good about it when they do.

### *Listing the “findings”*

In addition to solving the immediate problem of “making the ski jump work,” encourage children to come up with a few statements that they can confidently say are always going to be true for this type of ski jump. Such statements, called “findings,” might be something like, “Smooth tracks (always) work better than rough ones.” Whenever you discuss the design and operational details of the activities in this project, go back to your *What Works?* chart and see if the children can agree on a small number of general statements that would apply to their ski jumps. The kind of findings that the children may discover in this activity are:

- The **higher** you release the marble, the faster it travels at the bottom of the slope.
- The **steeper** the down slope, the faster the marble travels at the bottom...
- ... but if the slope is **too steep**, the marble bounces off at the curve.
- The **faster** the marble travels at take-off, the **farther** it goes (for a fixed launch angle).
- There is **one particular launch angle** that sends the marble farthest.

Keep track of these statements on the *What Works?* chart (or create a new chart as described below). Add items to the list whenever there is general agreement about them. If there is controversy about a particular point, you might keep a separate list or you might add it to the list in such a way that it is clearly temporary until it is finally admitted or rejected altogether based on later experience. Another option is to have a chart with two columns labeled: “What we know FOR SURE” and “What we THINK we know.”

It is important that you do not say whether you think a proposed finding is right or wrong. Your role is to insist that before a statement is accepted as true, it must be tested. So if someone says that the best angle for the launching end of the tube is about halfway between straight up and level, you can ask: “How do we know that? Have you tested it? How could you test it?”

### ***Consistency and accuracy***

For most man-made objects and devices to be considered “useful,” they must function in a consistent manner. Part of the engineering challenge for the children is to get the ball to fall in a can most or all of the time. Given the nature of the materials and the support system, this may not happen.

When they are testing their set-ups, you should encourage children to find out how consistent their tracks are. Does the ball always travel the full course of the tubing without falling off? If not, can they adjust the track so the ball stays on for the full ride?

Then, can they get the ball to fall into a can every time? This is a matter of accuracy. It is partly dependent on a consistent track and where and how the ball is released. If the track is at the right angle and the ball is released consistently at the same height and in the same way, it is highly likely that it will land in a can making the system accurate.

Once a product has been designed, constructed, and given its final tests, engineers need to carry out multiple testing to see if the product is consistent in its function and that it performs within the prescribed limits.

## SCIENCE BACKGROUND

### Trajectory

When the marble leaps off the end of the ski jump, it keeps going forward through the air and either rises up or drops toward the floor at the same time. How far forward it goes depends on two things:

- how fast it is going at take-off, and
- which way it is pointing at take-off.

When you let go of the marble, gravity pulls it down the track toward the floor. As it rolls down the track, it moves faster and faster (assuming that friction isn't too great). For any given track and ball combination, you can change three things:

- how high you start the marble,
- how steep the track is, and
- the placement and angle of the curve.

If your track is too steep, the marble goes into freefall and may bounce out of the track when it finally makes contact. But generally, the steeper the slope and the higher the starting point, the faster the marble will be traveling when it reaches the bottom.

To make the marble take off, however, the track has to curve back upwards at the bottom. This redirects all the speed and momentum the marble has gained on the down slope and sends it up again. But even at high speed, the marble won't jump very far if it takes off in the wrong direction. If the track points straight at the floor, that's where the marble will go. If the track curves up into a very steep uphill, it will go straight up in the air and fall close to the end of the track.

Through trial and error, you will find that there is one optimum angle for distance, and another optimum angle for height.

## ASSESSMENT

At the end of each session of this activity, ask yourself the following questions:

- Have the children made a ski jump that makes the marble jump about 2 or 3 feet (or more)?
- Do the children understand how they made the ski jump?
- Can they describe to you and to each other the process they went through to decide on a design and why it worked (or didn't work)?

Over the span of this project you should also look out for more general behavior changes relating to how well the children work as a large group and as small cooperative teams. It is probably too early to expect dramatic changes in these behaviors, but if you are attentive to their behaviors from the beginning, you can more easily see when changes occur.

- Do the children take turns and share the hands-on work?
- Do they ask each other for help before asking you?
- Do they listen when their peers are sharing ideas?
- Do they respond constructively to ideas from peers or adults?

## EXTENSIONS

### High jump

If time allows, have each team set up a high jump at the end of their tracks.

- Fold a piece of stiff paper (index card, oak tag, or file folder) in half so it can stand on its own.
- Place the folded paper (high jump bar) on top of books (see Figure 1.2) and have the children release a marble to see if it can jump over the bar. Change the position of the bar and the shape of the track until you get the marble to jump as high as possible.
- The bottom curve of the track should be taped to the floor so as to make measuring the height of the jump easy and standard for all teams. Measure the height of the jump from the floor to the tip of the bar that the marble jumped over (see Figure 1.3).

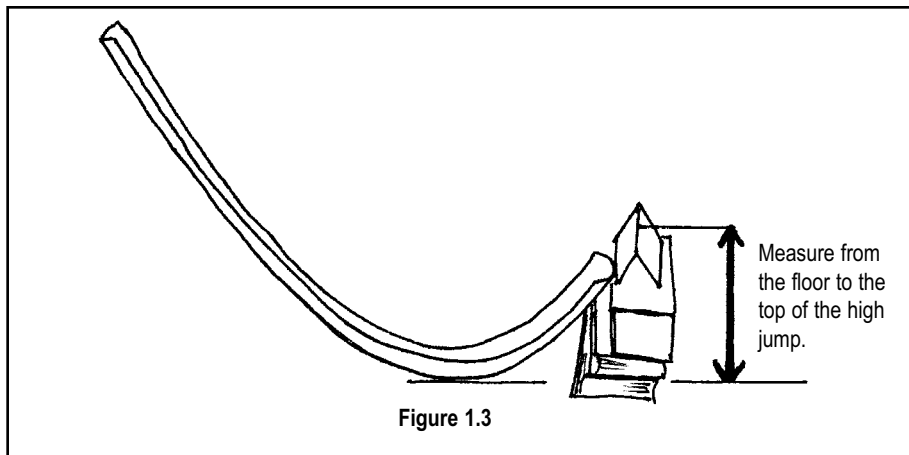

### Which marble works best?

Investigate whether one type of marble is a better jumper than another.

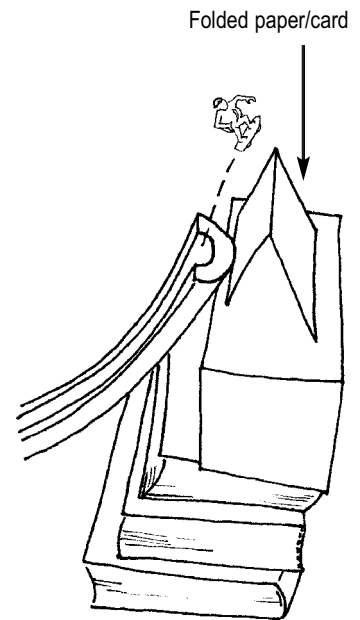

Figure 1.2  
High jump.